

RIVCLINCH® 0404 IP

Light and fast clinching tool

- Repositioning of the air silencer to avoid breakage
- Facilitated access to the greaser
- Additional suspension integrated into the back of the body for vertical hanging
- Internal air circulation optimization avoiding air contamination therefore better reliability
- Air hoses integrated into the body to reinforce solidity

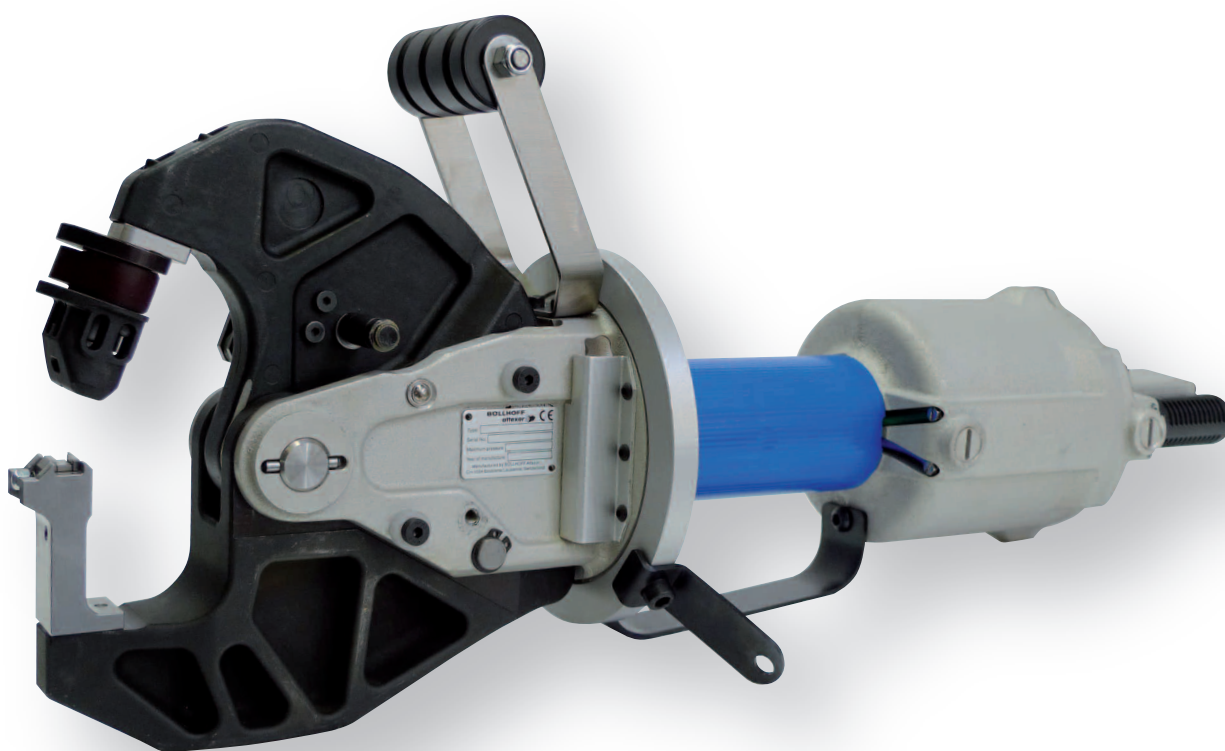

NEW

BÖLLHOFF
attexor



RIVCLINCH® 0404 IP

Clinching with the split-die technique

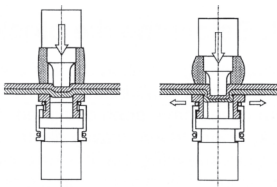

When clinching two or more layers of sheet metal, the material is plastically deformed inside a die through a squeezing process between the punch and the anvil. The joint is created as the material flows sideways pushing out the mobile die blades.

The result is a high quality joint, without the need for consumables such as screws or rivets, and without disturbing the coating, thus eliminating the need for post touch-up work as occurs with welding. The built-in easy end-of-stroke setting nut of the RIVCLINCH® 0404 IP has the ability to run various applications.

In addition, the flexibility of the RIVCLINCH® 0404 IP tool kits allows for clinching various thicknesses and material combinations without resetting the tooling.

A plug-and play hand tool for jobsite

This radically new and extremely productive clinching tool is a plug-and-play light weight portable fastening tool, particularly suited for jobsite assembly. It is 100% pneumatic, and is actuated by a built-in mechanical amplifier producing the high tool force required for a quality clinch joint.

One-hand operation

The unique patented self-locking mechanism offer comfort and safety to the operator and allows easy access due the large opening of the jaw. The operator controls both the soft closing/opening jaw actuator and work stroke producing the joint with one hand. The light weight (6kg / 13 lbs) and the one-hand control allows the operator to use the free hand for holding in place the parts to be joined.

Short pay-back

Due to the high productivity, long lasting tooling, and the absence of any consumable or any heavy installation such as hydraulic power pack or electric transformer, the investment pay-back can be exceptionally short.

Absolutely tight clinching point in the air duct:

It is certified according to DIN 1507:2006 for the air duct construction and guarantees an achievement of air tightness class D, in Germany.



Technical specifications

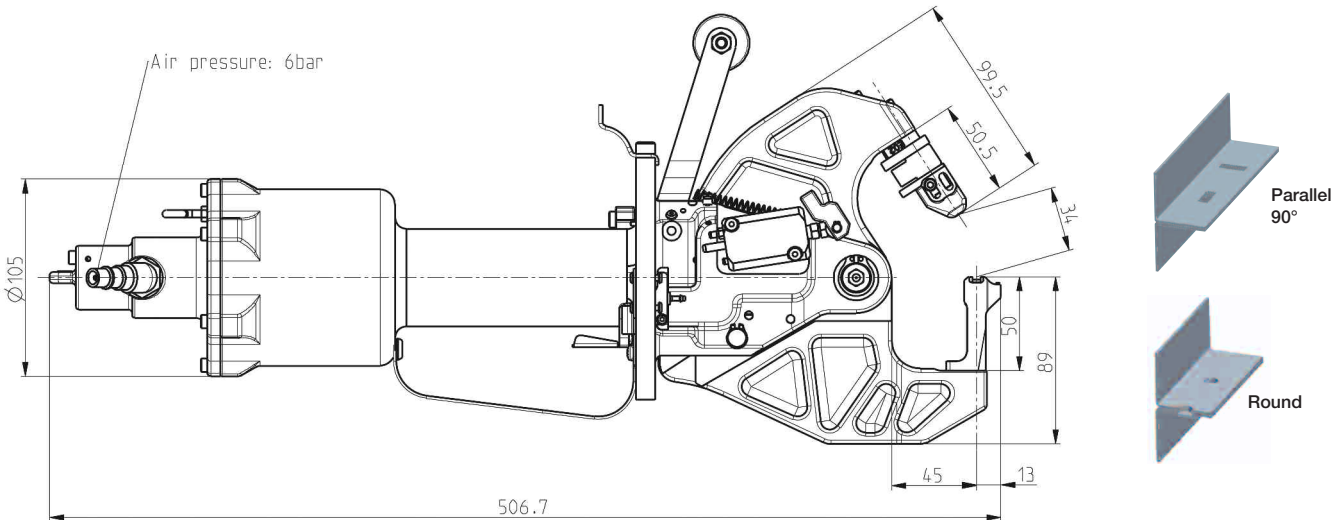

Accessories

The machine is delivered complete, ready to use. Air preparation unit, a gyroscopic suspension ring and a balancer are available as options.

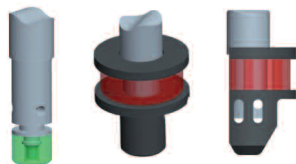

Tool kits

The tool kits have to be selected from the original RIVCLINCH® series ST432 (rectangular, 90° or parallel), or SR 503 (round) based on the application.

Weight of work head with gyroscopic suspension	6 kg
Working air pressure	6 bar
Tool force at 6 bar	35 kN
Cycle time	0.5 – 0.9 sec
Work stroke	7 mm
Jaws opening	34 mm
Depth of jaw	45 mm
Max. total thickness, mild steel 2 layers	3.0 mm
Max. total thickness, mild steel 3 layers	3.5 mm
Max. total thickness, stainless steel	2.5 mm

